

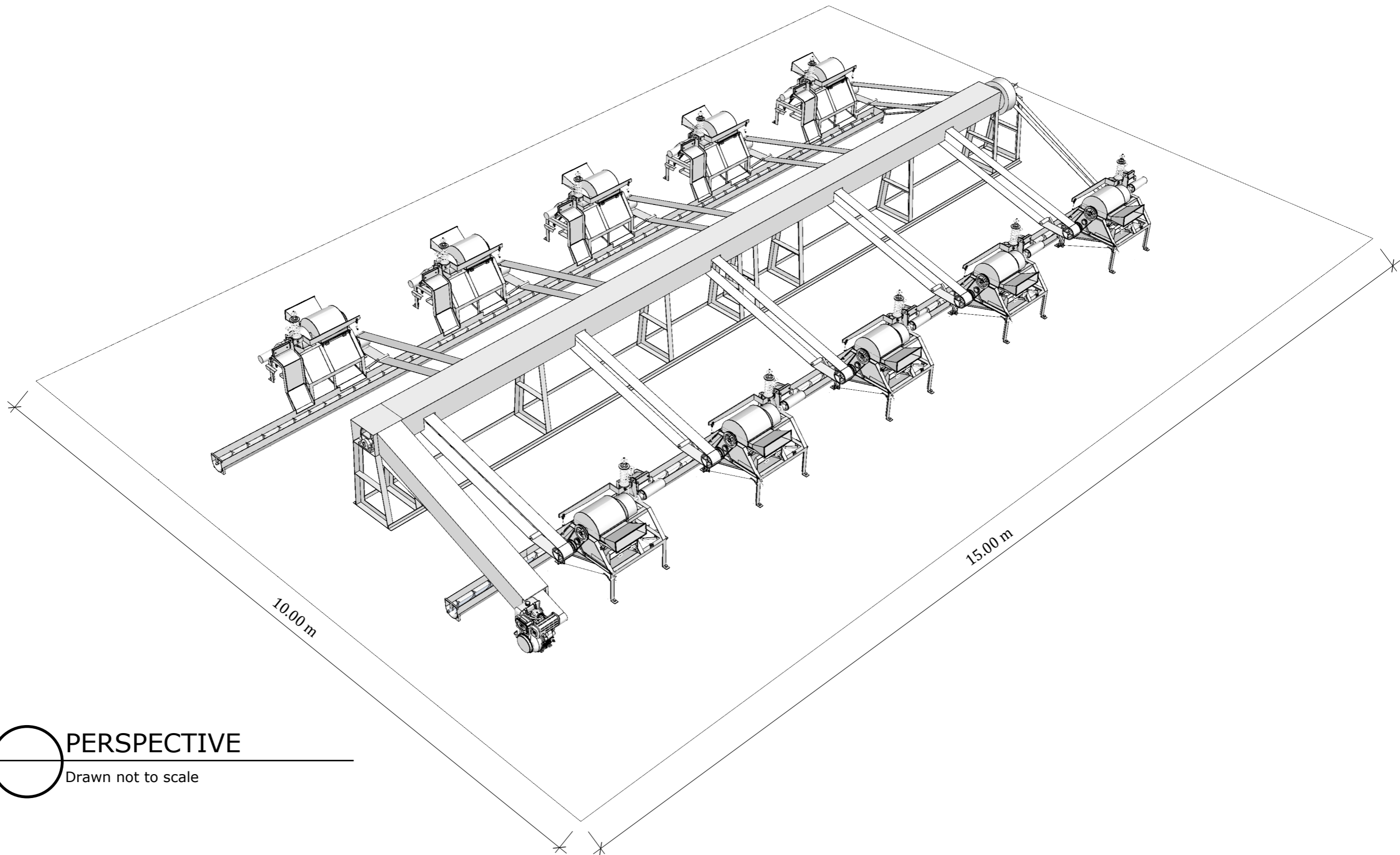

SERIES TYPE COMBINED ABACA DECO-SPINDLE EXTRACTION MACHINE (10 SERIES)



PHILIPPINE FIBER INDUSTRY DEVELOPMENT AUTHORITY
3/F PCAF BUILDING, DA COMPOUND, ELLIPTICAL ROAD,
DILIMAN, QUEZON CITY



PERSPECTIVE
 Drawn not to scale

OWNER:	PROJECT TITLE	SHEET CONTENT	DRAWN/PREPARED & DESIGNED BY:	REVIEWED BY:	RECOMMENDING APPROVAL	APPROVED :	
	PHILIPPINE FIBER INDUSTRY DEVELOPMENT AUTHORITY 3/F PCAF BUILDING, DA COMPOUND, ELLIPTICAL ROAD, DILIMAN, QUEZON CITY	SERIES TYPE COMBINED ABACA DECO-SPINDLE EXTRACTION MACHINE (10 SERIES)	AS SHOWN	ENGR. BILLY JOEL C. ABEJERO/ ENGR. IRMA R. RODIS	ENGR. IRMA R. RODIS	ENGR. MARIETA A. RODRIGUEZ	KENNEDY T. COSTALES
				ABE GIP/ ENGINEER II PRC: 10570/ PRC: 3859	ENGINEER II/HEAD, EPDSS	OIC -INTERIM FIBER ENGINEERING DIVISION	EXECUTIVE DIRECTOR III

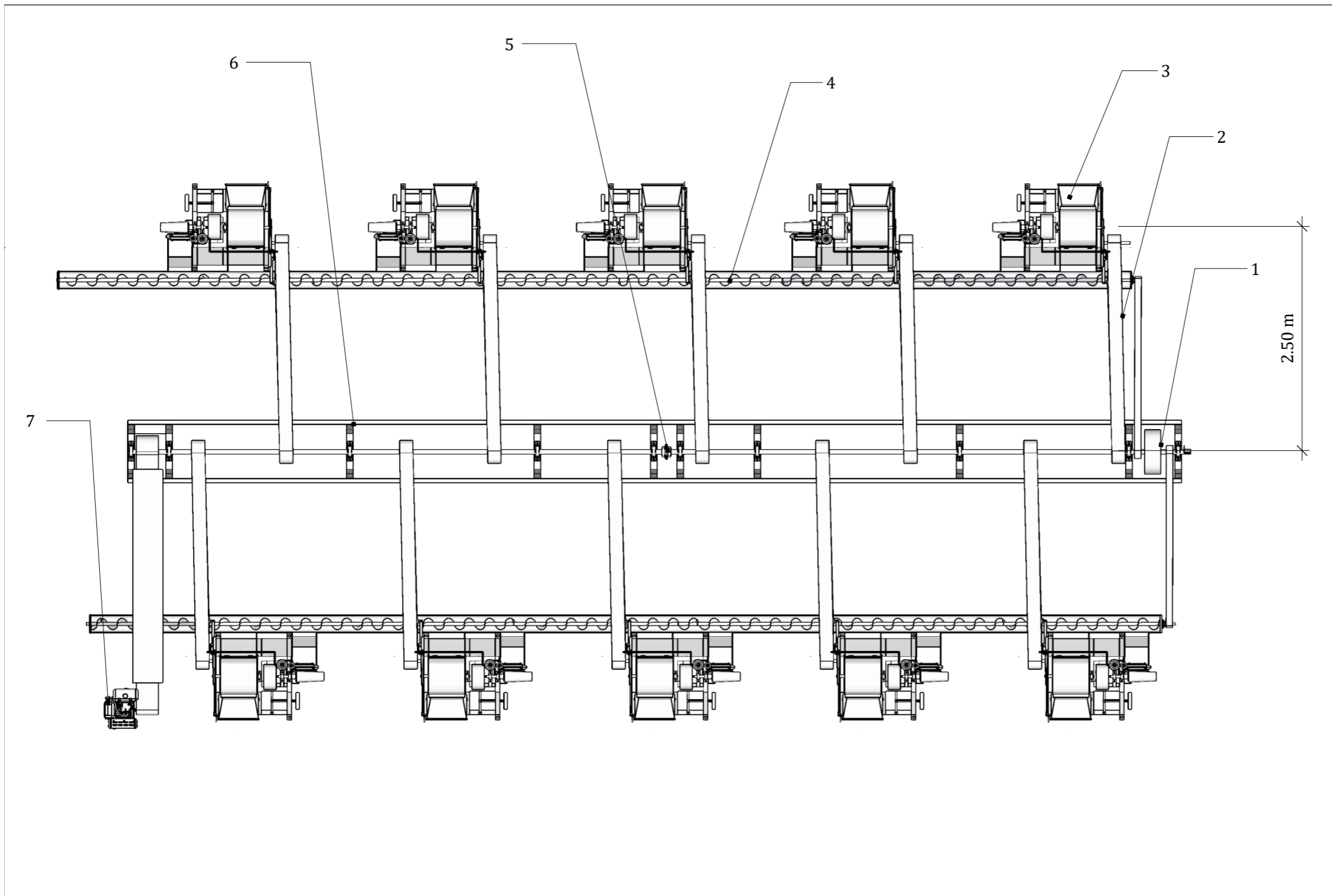

TOP VIEW
 Scale 1:50 mm

LEGEND	
NO.	PARTS
1	300 KG FLYWHEEL (700mmx180mm)
2	FLAT BELT
3	COMBINE ABACA DECO-SPINDLE EXTRACTION MACHINE
4	STRIPPING WASTE DISPOSAL BIN HORIZONTAL SCREW TYPE CONVEYOR
5	FLANGE COUPLING
6	A FRAME
7	24 HP INTERNAL COMBUSTION ENGINE DIESEL ENGINE (WATER-COOLED WITH STARTER)

OWNER:	PROJECT TITLE	SHEET CONTENT	DRAWN/PREPARED & DESIGNED BY:	REVIEWED BY:	RECOMMENDING APPROVAL	APPROVED :	
PHILIPPINE FIBER INDUSTRY DEVELOPMENT AUTHORITY 3/F PCAF BUILDING, DA COMPOUND, ELLIPTICAL ROAD, DILIMAN, QUEZON CITY	SERIES TYPE COMBINED ABACA DECO-SPINDLE EXTRACTION MACHINE (10 SERIES)	AS SHOWN	ENGR. BILLY JOEL C. ABEJERO/ ENGR. IRMA R. RODIS	ENGR. IRMA R. RODIS	ENGR. MARIETA A. RODRIGUEZ	KENNEDY T. COSTALES	<div style="border: 1px solid black; border-radius: 50%; width: 30px; height: 30px; display: flex; flex-direction: column; justify-content: center; align-items: center;"> 2 11 </div>
			ABE GIP/ ENGINEER II PRC: 10570/ PRC: 3859	ENGINEER II/HEAD, EPDSS	OIC -INTERIM FIBER ENGINEERING DIVISION	EXECUTIVE DIRECTOR III	