

MASK
Isometric view
SCALE(20/30)
SCALE(A3)

HTB
NTS

OWNER PHILIPPINE FIBER INDUSTRY DEVELOPMENT AUTHORITY 3/F FARMER BLDG. DEPARTMENT OF AGRICULTURE ELLIPTICAL ROAD, DILMAN, QUEZON CITY	PROJECT TITLE/LOCATION Modified Abaca Stripping Knife (MASK)	SHEET CONTENTS AS SHOWN	PREPARED & DESIGN BY ENGR. ROMY ALVINO DOMINGO FOO/II	REVIEWED ENGR. IRMA ROLLON RODIS ENGR. II	RECOMMENDING APPROVAL ENGR. MARIETA A. RODRIGUEZ OIC - IFEED	APPROVED KENNEDY COSTALES EXECUTIVE DIRECTOR	SHEET NO M1 4
							

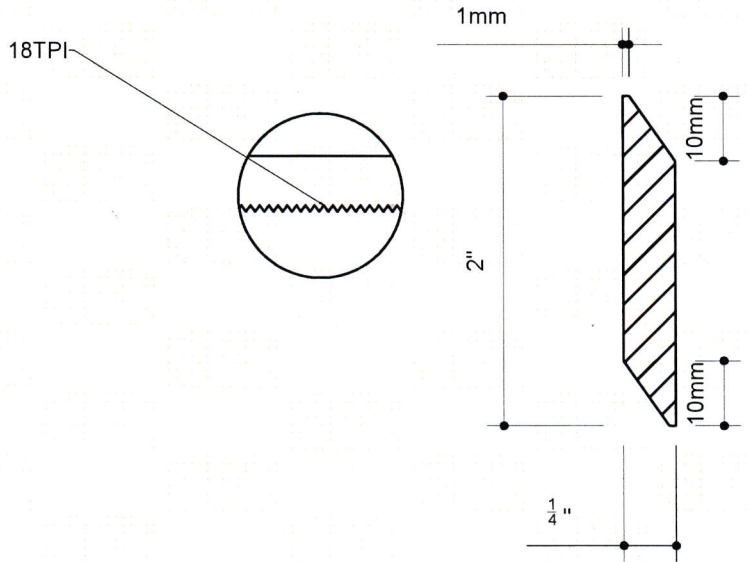

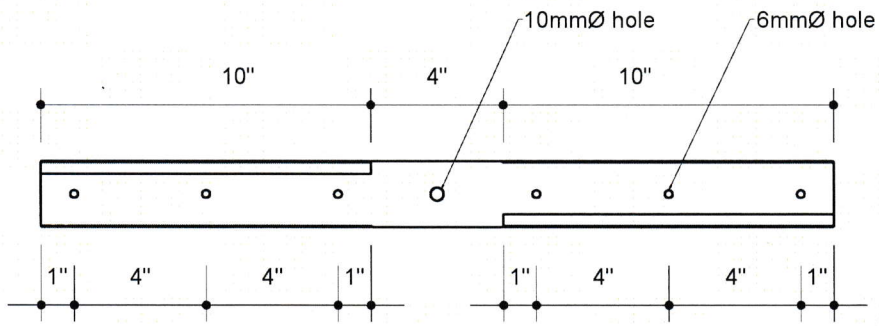

A
 MASK
 Details of Stripping Knife
 SCALE(20X30)
 SCALE(A5)
 NTS
 NTS

OWNER PHILIPPINE FIBER INDUSTRY DEVELOPMENT AUTHORITY 3/F - MARINA BUILDING, 1000 SHAW BLVD. SUITE 301, ALABANG, MARIKINA CITY, RIZAL	PROJECT TITLE/LOCATION Modified Abaca Stripping Knife (MASK)	SHEET CONTENTS	AS SHOWN	PREPARED & DESIGN BY ENGR. ROMY AWIN D. DOMINGO FOO II	REVIEWED	ENGR. IRMA ROLLON RODIS ENGR. II	REVISIONS APPROVAL <i>Marieta A. Rodriguez</i> ENGR. MARIETA A. RODRIGUEZ D/C - I/ED	APPROVED <i>[Signature]</i> KENNEDY COSTALES EXECUTIVE DIRECTOR	SHEET NO. M3 4



